

## LIFE CYCLE ASSESSMENT OF UHPC BRIDGE CONSTRUCTIONS: SHERBROOKE FOOTBRIDGE, KASSEL GÄRTNERPLATZ FOOTBRIDGE AND WAPELLO ROAD BRIDGE

Thorsten STENDEL<sup>a</sup>, Peter SCHIEBL<sup>b</sup>

<sup>a</sup> Dr.; Centre for Building Materials (cbm), Technische Universität München (TUM) Baumbachstr. 7, 81245 München  
E-mail address: *Stengel@cbm.bv.tum.de*

<sup>b</sup> Prof.; Centre for Building Materials (cbm), Technische Universität München (TUM) Baumbachstr. 7, 81245 München

Received: 04.11.2008; Revised: 05.01.2009; Accepted: 02.02.2009

### Abstract

The paper presents the results of life cycle assessments (LCA) performed for three bridges in which UHPC was an essential part of the structure. The bridges investigated are the Sherbrooke footbridge in Canada, the Kassel Gärtnerplatz footbridge in Germany and the Wapello road bridge in USA. The life cycle assessment was performed using the Swiss process and material database ecoinvent. The ecological effects of global warming (GWP100), depletion of the stratospheric ozone (ODP), photo-oxidant formation (POCP), acidification (AP) and eutrophication (NP) were adopted as impact category indicators according to the Dutch CML method. The results show that UHPC used in the Sherbrooke footbridge and the Gärtnerplatz footbridge causes approximately 60 to 85% of the environmental impact. In addition, appreciable contributions are made by the steel truss and the prestressing of the UHPC. In case of the Wapello road bridge, the contribution of UHPC to environmental impact was from 44 to 74% somewhat smaller. As well as UHPC, in particular normal concrete in the bridge deck, the steel reinforcement of the bridge deck and the prestressing of the UHPC contribute appreciably to the effect on the environment. The present contribution is a summary of a paper presented in 2008 AMCM conference.

### Streszczenie

W artykule przedstawiono wyniki analizy całego cyklu użytkowania przeprowadzonej dla trzech mostów, w których betony ultra-wysokiej wytrzymałości (BUWW) stanowiły istotną część konstrukcji. Badane obiekty mostowe to: kładka dla pieszych w Sherbrooke w Kanadzie, kładka dla pieszych Gärtnerplatz w Kassel w Niemczech oraz most drogowy w Wapello w USA. Analiza całego cyklu użytkowania przeprowadzona została z wykorzystaniem procedury szwajcarskiej i materiałowej bazy danych ecoinvent. Ekologiczne efekty globalnego ocieplenia, zubożenie ozonu stratosferycznego, tworzenie się foto utleniacza, zakwaszanie i eutrofizacja zostały zaadaptowane jako wskaźniki kategorii wpływu zgodne z holenderską metodą CML. Wyniki analizy pokazały, że beton ultra-wysokiej wytrzymałości użyty do budowy kładki dla pieszych w Sherbrooke i kładki dla pieszych Gärtnerplatz powoduje około 60 do 85% wpływów środowiskowych. Ponadto, znaczny udział miały również stalowe kratownice i sprężanie BUWW. W przypadku mostu w Wapello, udział betonu ultra-wysokiej wytrzymałości we wpływach środowiskowych był nieznacznie mniejszy i wynosił 44 do 74%. Zarówno BUWW, a w szczególności beton zwykły w jezdni mostowej, zbrojenie jezdni mostowej i sprężanie BUWW przyczyniły się znacząco do wpływu na środowisko. Przedstawiana praca jest podsumowaniem referatu prezentowanego w 2008 roku na konferencji AMCM.

**Keywords:** Building simulation; Heat outflow; Thermovision; Thermal bridges; Temperature field; ESP-r.

## 1. INTRODUCTION

Structures made with normal concrete are usually heavy and require considerable quantities of raw materials. For structures made to span large distances, the dimension of the span is usually limited by the weight of the structure itself. In case of UHPC,

increased strength lowers the mass to strength ratio providing for more economical deployment of resources. Slender and light structural components which are aesthetically pleasing can be made with UHPC without lowering load bearing capacity. UHPC opens up a field of completely new possibilities. However, a disadvantage of UHPC is its cement content which,

according to current technological practice, is raised well above that of normal concrete. Moreover, the high content of high-performance superplasticizer, the use of micro steel fibres and, if required, heat treatment increase the demand for resources and energy. These factors partially offset the advantages of a low mass to strength ratio. The extent to which the environmental effect of constructions can be reduced by using the new material UHPC is currently being investigated in the project at the cbm (Centre for Building Materials) of the Technische Universität München. Results obtained for the life cycle assessment of bridges where UHPC is an essential component of the structure are presented in this contribution. The bridges investigated are the Sherbrooke footbridge in Canada, the Kassel Gärtnerplatz footbridge in Germany and the Wapello road bridge (Mars hill bridge) in USA. It is not intended to compare the bridges with each other, but create a basis regarding aspects of sustainability. Thus in the further course of the research project, conventional bridges of similar span and load bearing capacity will be investigated with regard to their environmental impact. Based on existing constructions, this study aims to determine whether and how the new building material UHPC can be applied in bridge construction in a sustainable manner.

## 2. LIFE CYCLE ASSESSMENT OF UHPC BRIDGES

### 2.1. General

The potential environmental impact of products and processes can be estimated by life cycle assessment (LCA) methods. The procedure is laid down in the series of international standards DIN EN ISO 14040 to DIN EN ISO 14043. The process and materials data necessary to perform the assessment is usually based on information provided by companies and organisations as well as the investigations of environmental institutions. Owing to the large amount of data, software tools and appropriate process and materials databases are usually implemented. The life cycle assessments presented in this contribution were performed on the basis of the Swiss process and materials database ecoinvent. The evaluation of the data was carried out with the CML method. The ecological effects of global warming (GWP100), depletion of the stratospheric ozone (ODP), photo-oxidant formation (POCP), acidification (AP) and eutrophication (NP) were adopted as impact category indicators according to an update of the Dutch CML

method, so-called CML 2 baseline 2000 V2.1.

### 2.2. System Boundaries

According to the ISO 14041 [1] guidelines, the system boundary is defined in a spatial context. System boundaries generally include the entire life cycle of a product, i.e. pre-manufacturing (raw material production, manufacture of parts and components), the actual manufacturing process, transport, application and disposal. The results performed up to now comprise only the assessment of the materials used for the bridges including the raw materials and the infrastructure necessary for production. Heat treatment of UHPC, transport to the construction site or prefabrication plant, construction, maintenance as well as disposal of the bridges has not yet been considered.

### 2.3. Functional Unit

#### 2.3.1. General

The functional unit is one section of each bridge without a foundation. Due to lack of information, the bridge railing is not considered in this study. Information on the construction and the materials used is taken from the literature. The most important functional characteristics, which are essential for construction engineering, are summarized in the following for the three bridges under consideration.

#### 2.3.2. Sherbrooke Footbridge

The world's first engineering structure designed with UHPC was the Sherbrooke footbridge in Sherbrooke, Quebec, built in 1997 [2], Figure 1, left.



Figure 1.  
General view of Sherbrooke footbridge (left-hand side)

Spanning 60 m, this precast, prestressed pedestrian bridge is a post-tensioned open-web space reactive powder concrete (RPC) truss with 4 access spans made of high performance concrete (HPC). The main span is an assembly of six 10 m prefabricated match-cast segments. The bridge deck is a thin slab 30 mm thick with prestressed (greased-sheathed monostrands) and transversal ribs every 1.25 m [2]. It is bedded on two longitudinal beams to which the diagonals are connected. The truss webs are made of RPC confined in stainless steel tubes, Figure 2.

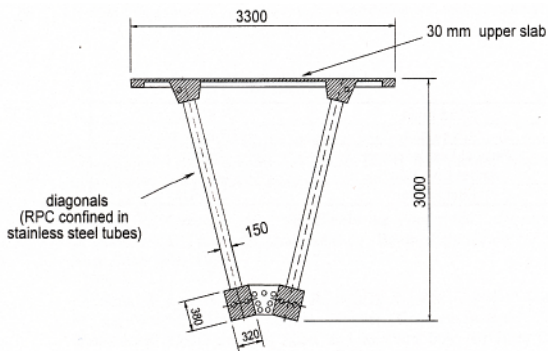

Figure 2.  
Typical cross section of the Sherbrooke footbridge truss after [2]

In cross section, the bottom flange is composed of two  $320 \times 380 \text{ mm}^2$  beams linked every 5 metres by a deviator. The structure is longitudinally prestressed by an internal prestressing placed in each longitudinal beam and an external prestressing anchored at the upper part of the end diaphragms and directed into blocks placed at the level of the lower flange. The connection between the beams and the truss diagonals is ensured by greased-sheathed monostrands and miniaturized anchorage specially designed for RPC [2]. In this type of structure, the global positive bending moment (due to weight and live load) results in compression in the upper beams and slab and tension in lower beams [3]. Here the tension is counterbalanced by post-tensioning. The relevant shear force results in direct tension/compression in diagonals. Once again the tension is counterbalanced by prestressing. All other secondary tensile effects are counterbalanced by the

fibres inside the materials [3]. The main characteristics concerning the longitudinal behaviour can be found in Table 1.

Table 1.  
Characteristic values of Sherbrooke footbridge truss [3]

Characteristic	Value
Dead Load	4.4 kN/m <sup>2</sup>
Live Load	3.9 kN/m <sup>2</sup>
Vertical Displacement under Live Load	48 mm
First Mode	2.45 Hz

The bridge was erected at a total cost of 425,000 US\$ and an extensive monitoring programme was implemented at a cost of 70,000 US\$ [2]. The four access spans were not taken into consideration for the LCA presented here. The functional unit is therefore the 60 m spanning RPC truss with the aforementioned characteristic values.

### 2.3.3. Gärtnerplatz Footbridge

The Gärtnerplatz hybrid bridge is one of the first applications of UHPC in Germany. It was constructed for pedestrians and cyclists and has a length of about 133.2 m with a maximum span of 36 m [4]. The bridge was conceived as a steel and UHPC composite space frame and consists of precast prestressed upper chords and precast prestressed bridge deck elements both made of UHPC. The lower chords and the diagonals are made with tubular steel. The diagonals are connected to the upper UHPC chords by a fully prestressed screw connection [5]. The upper chord measures approximately  $30 \times 40 \text{ cm}^2$ . In a new approach, the 8 to 10 cm thick bridge deck elements are glued to the upper chords without any mechanical connection [4]. Between the ramps, the bridge has six sections with lengths between 12 to 36 m [4], Figure 3.

A cross sectional view of the Gärtnerplatz footbridge is shown in Figure 4. Concerning the load bearing capacity of the Gärtnerplatz footbridge, only a design value of 50 kN is mentioned in [7]. Further design details are not available. The functional unit for this study consists of the six bridge sections between both ramps.

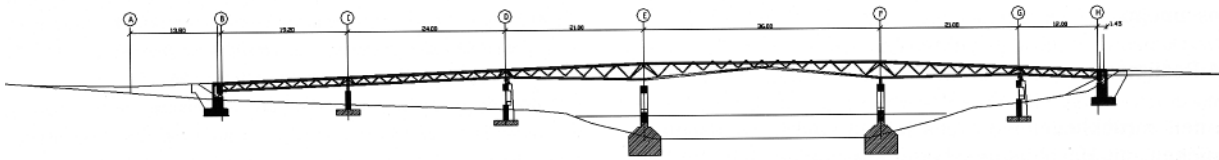

Figure 3.  
Longitudinal section of Gärtnerplatz footbridge [4]

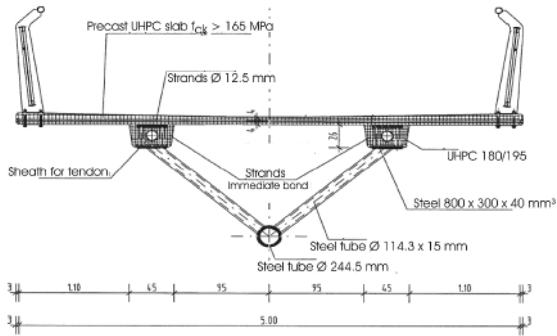

Figure 4. Cross section of Gärtnerplatz footbridge after [6]

### 2.3.4. Wapello Road Bridge (Mars Hill Bridge)

In 2003, Wapello County and the Iowa Department of Transportation used UHPC in prestressed concrete beams in a bridge replacement project. The beams are pretensioned using 15.4 mm diameter low relaxation strands [8]. No reinforcing steel except to provide composite action between the beam and cast-in-place deck was used [8]. The replacement bridge is a 34 m simple span bridge with a three beam cross section and a total width of 8.3 m [8]. The abutments

are integral and a 203 mm cast-in-place deck is used [8]. Beam spacing is roughly 2.9 m with approximately 1.2 m overhangs. See figure 5 for details on the cross section [8].

The final beam design section used 49 25.4 mm strands stressed to 72.6% of ultimate strength. To reduce end beam stresses, five strands were draped along with debonding, figure 6.

According to [8] the Wapello road bridge is designed for LRFD HL-93 loading. This means that a load of 325 kN applied by a design truck or tandem and a 9.3 kN/m design lane load [9], Figure 7. The functional unit used in this study is the single span bridge without abutments and bridge parapet.

### 2.4. Materials Used and Origin of Materials Data

#### 2.4.1. General

The life cycle inventory analysis and impact assessment were carried out using SimaPro version 7.1 software [10]. The data required to construct a product were retrieved from the ecoinvent database [11] as well as from our own data compilation [12, 13]. In the following, the materials and the amounts used are determined for each of the three bridges.

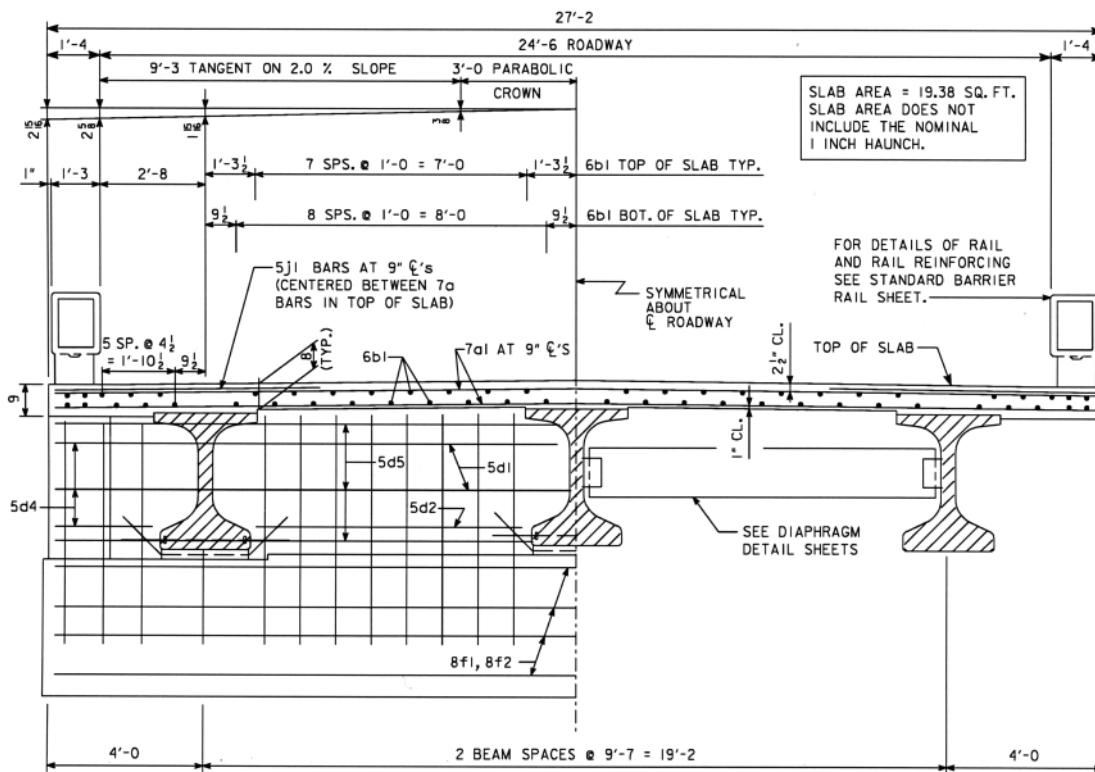

Figure 5. Cross section of Wapello Road Bridge [8]



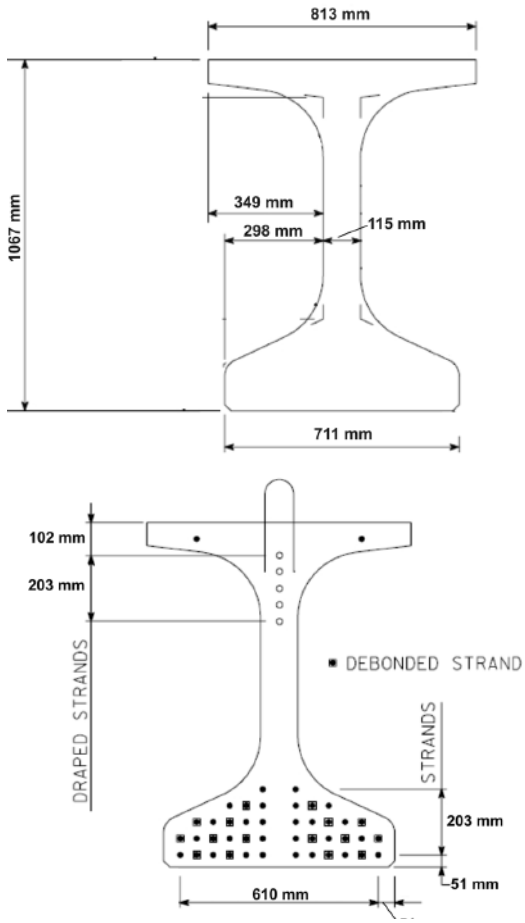

Figure 6. Cross section and strand layout of Wapello road bridge beams after [8]

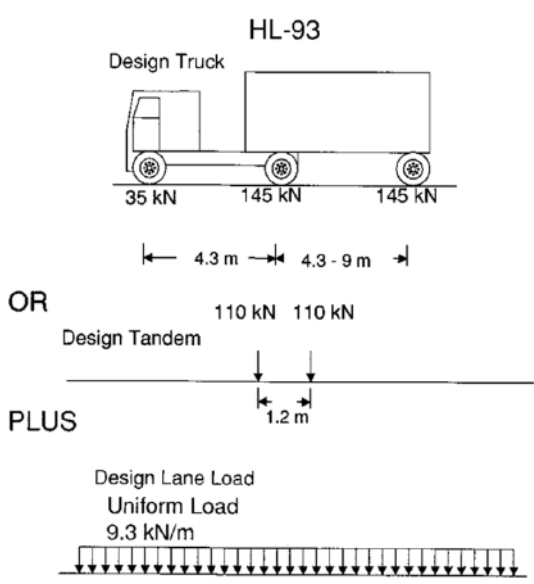

Figure 7. HL-93 loading after [9]

2.4.2. Sherbrooke Footbridge Truss

The Sherbrooke footbridge truss is made entirely of RPC, both confined and unconfined, containing fine steel fibres ( $\varnothing_f = 0.2 \text{ mm}$ ,  $l_f = 25 \text{ mm}$ ) [2]. The maximum particle size is 0.6 mm [2]. The prestressing strands are 12 mm in diameter for the upper deck transverse ribs and 13 mm in diameter for the truss diagonals and the longitudinal prestressing [2]. The composition of the RPC is in Table 2. This should correspond to the composition of Ductal® which was used for the Sherbrooke footbridge according to [14]. The RPC truss webs are confined in stainless steel tubes.

Table 2. Composition of the RPC for Sherbrooke footbridge truss [2]

Component	Amount
Cement ASTM Type 2	710 kg/m <sup>3</sup>
Silica fume	230 kg/m <sup>3</sup>
Ground quartz	210 kg/m <sup>3</sup>
Silica sand	1010 kg/m <sup>3</sup>
Steel fibre $\varnothing = 0.2 \text{ mm}$ , $l = 25 \text{ mm}$	190 kg/m <sup>3</sup>
Superplasticizer	19 l/m <sup>3</sup>
Water	200 l/m <sup>3</sup>

The quantities of materials used for the bridge were derived from the specifications on the dimensions of the Sherbrooke footbridge in [2]. Apart from the micro steel fibres and superplasticizer, it was possible to represent all the materials used for the bridge with the help of the ecoinvent data sets. The micro steel fibres and superplasticizer were taken into account by using results in [12, 13].

2.4.3. Gärtnerplatz Footbridge

The values published for the composition of the UHPC are contradictory. A steel fibre content of approximately 1 vol.% is mentioned [5, 7, 15, 16]. Opposed to this, the content of fibres is between 2 and 2.5 vol.% according to [17, 18]. Enquiries at the University of Kassel confirmed a fibre content of 2.5 vol.%. Different values for the content of mineral components were also found. In this study a cement content of 733 kg/m<sup>3</sup>, a silica sand content of 1091 kg/m<sup>3</sup>, a quartz powder content of 183 kg/m<sup>3</sup>, a silica fume content of 230 kg/m<sup>3</sup>, a water content of 161 kg/m<sup>3</sup>, a steel fibre content of 192 kg/m<sup>3</sup> and a superplasticizer content of 30 kg/m<sup>3</sup> was assumed. The transversal prestress in the bridge deck is applied by strands with diameter of 12.5 mm [6]. The number of strands per bridge deck was determined at 7 per ele-

ment by inspecting a photo in [2], Figure 8. The dimensions of an element was  $5.0 \times 2.0 \text{ m}^2$ , the thickness was 10 cm on average [5, 19]. Both UHPC top beams (mean cross section  $30 \times 40 \text{ cm}^2$ ) beneath the bridge deck elements were each pretensioned by ten strands in the stressing mould and after assembly each by inner tendons without connection in a sheet with a diameter of 125 mm [5, 19]. Since no further information on the strands is available, it is assumed that they are 12.5 mm in diameter.

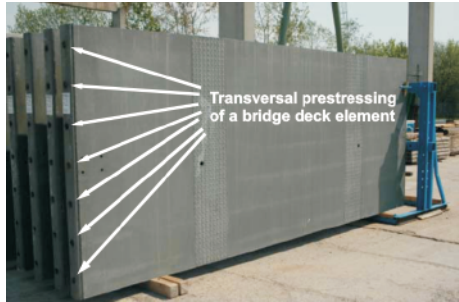

Figure 8. Transversal prestressing of a bridge deck element, original photo taken from [20]

According to [19], the post tensioning (unconnected) tendons without bond each have a cross section of  $18.0 \text{ cm}^2$ . The bridge deck elements were glued with an epoxy resin mortar to the 40 cm wide top chords [19]. The epoxy resin mortar consists of approximately 22 wt.% (corresponds to roughly 38 vol.%) two-component epoxy resin and roughly 78 wt.% (corresponds to roughly 62 vol.%) quartz powder as a filler [19]. A joint width of 6.0 mm was assumed because an exact value was not available. The web structure consists of welded steel tubes of steel quality S355J2G3 [19]. The diagonals have an outer diameter of 114.3 mm and a thickness of 16 mm. Thus the mass per metre of steel tube is 38.8 kg/m. Based on technical drawings of the bridge, the total length of the diagonals was estimated to be 450 m. The bottom chords of the steel web have a diameter of 244.5 mm. It has a thickness of 30 mm in the central span and 20 mm in the remaining spans [19]. To make the analysis easier, a mean mass per length of 135 kg/m was assumed to be valid for the whole length of the bottom chord. The total length of the bottom chord is 150 m. The material quantities used for the whole bridge were derived from the above dimensions specified for the Gärtnerplatz footbridge. With the exception of the superplasticizer and micro steel fibres, it was possible to represent directly all the above mentioned materials with ecoinvent data sets. The micro steel fibres

and the superplasticizer were accounted for with the help of the results in [12, 13].

#### 2.4.4. Wapello Road Bridge

The pavement deck of the Wapello road bridge is made of normal concrete with a thickness of 20.3 cm [22] which was cast in place on the UHPC beams. Since no detailed specifications are available, it was estimated from the plans that the reinforcement of the pavement deck consists uniformly of reinforcing steel with a diameter of 28 mm. A total of  $50 \text{ m}^3$  UHPC based on Ductal®-Premix was used to produce the three prestressed beams [21]. The composition of the UHPC is shown in Table 3.

Table 3. Composition of the UHPC for Wapello road bridge [23]

Component	Value
Ductal® CS 1000 Premix	2194 kg/m <sup>3</sup>
Metallic fibre ( $\varnothing_f = 0.2 \text{ mm}$ , $l_f = 13 \text{ mm}$ )	156 kg/m <sup>3</sup>
Superplasticizer	30 kg/m <sup>3</sup>
Water	131 kg/m <sup>3</sup>

Since no further specifications are available for Ductal®-Premix, the composition of the mineral components listed in Table 2 was assumed. With the exception of the superplasticizer and micro steel fibres, it was possible to represent directly all the above mentioned materials with ecoinvent data sets. The micro steel fibres and the superplasticizer were accounted for with the help of the results in [12, 13].

#### 2.5. Assumptions and Limitations

It should be pointed out that estimates had to be made for the production data owing to insufficient technical information on some of the materials and the amounts used for the bridges. Transport processes are only in the processes adopted from ecoinvent. This concerns only the production of electric steel as well as the provision of auxiliary substances and energy included in ecoinvent. Other transport processes were not considered in modelling and combining the datasets. This approach was taken to permit a more flexible application of the present results in future studies. It is therefore possible to extend the results if knowledge on the actual transport processes is available. Moreover, as already mentioned, the assembly of the components, servicing of the bridge during its utilization and demolition at the end of its service life were not taken into consideration.

### 3. RESULTS OF THE LCA

#### 3.1. Impact Categories

Classification and characterization following ISO 14042 guidelines were applied to analyze the potential environmental impact. The ecological effects of global warming (GWP100), depletion of the stratospheric ozone (ODP), photo-oxidant formation (POCP), acidification (AP) and eutrophication (NP) were adopted as impact category indicators. These impact category indicators were assessed according to an update of the Dutch CML method included in SimaPro, so-called CML 2 baseline 2000 V2.1. This method elaborates the problem-oriented (midpoint) approach for the first group, so called obligatory impact category group (or baseline indicator group), provided by the CML guide.

#### 3.2. Sherbrooke Footbridge Truss

Figure 9 shows the results of the environmental impact assessment for the Sherbrooke footbridge truss. The potential environmental impact by the production of the materials used for the Sherbrooke footbridge truss is GWP100:  $4.45 \times 10^4$  kg CO<sub>2</sub> eq, ODP:  $1.85 \times 10^{-3}$  kg CFC-11 eq, POCP: 21.6 kg C<sub>2</sub>H<sub>4</sub> eq, AP: 161.5 kg SO<sub>2</sub> eq and NP: 18.7 kg PO<sub>4</sub><sup>3-</sup> eq.

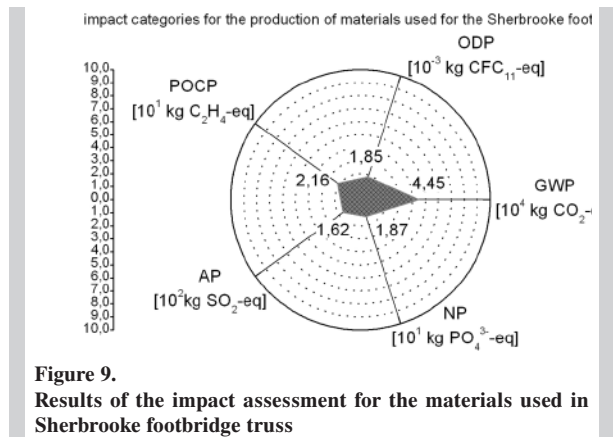

The contributions of the different materials to the potential environmental effect may be taken from the results of the dominance analysis, Figure 10. Depending on the impact category, the UHPC used contributes between about 60 to 84% to the environmental effect of the Sherbrooke footbridge truss. The stainless steel tubes contribute between about 3 and 10% and the strands and anchors together between roughly 12 and 28%. The effect of the mixing water

for the UHPC is negligible and has thus not been included in the results.

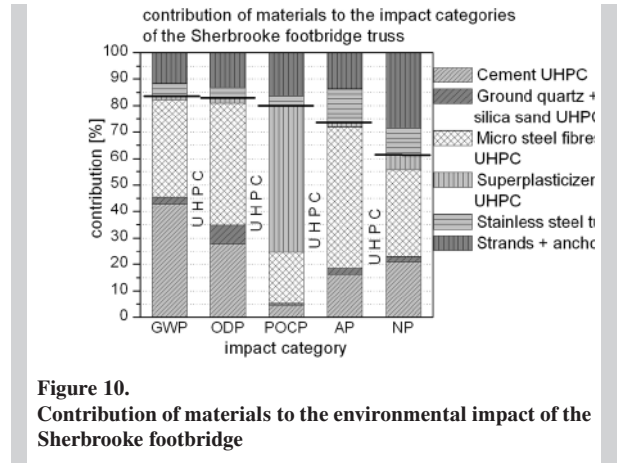

Figure 10. Contribution of materials to the environmental impact of the Sherbrooke footbridge

#### 3.3. Gärtnerplatz Footbridge

Figure 11 shows the results of the environmental impact assessment for the Gärtnerplatz footbridge. The potential environmental impact by the production of the materials used for the Gärtnerplatz footbridge is GWP100:  $12.1 \times 10^4$  kg CO<sub>2</sub> eq, ODP:  $5.6 \times 10^{-3}$  kg CFC-11 eq, POCP: 72.4 kg C<sub>2</sub>H<sub>4</sub> eq, AP: 423.7 kg SO<sub>2</sub> eq and NP: 50.5 kg PO<sub>4</sub><sup>3-</sup> eq. The contributions of the different materials to the potential environmental effect may be taken from the results of the dominance analysis, Figure 12. Depending on the impact category, the UHPC used contributes between about 72 to 85% to the environmental effect of the Gärtnerplatz footbridge.

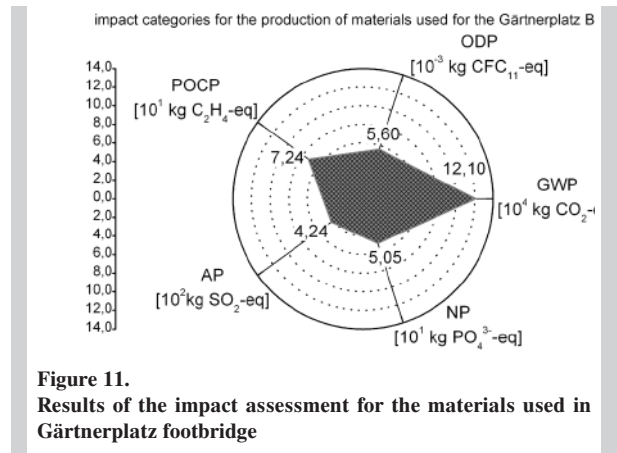

Figure 11. Results of the impact assessment for the materials used in Gärtnerplatz footbridge

The stainless steel tubes of the web diagonals contribute between about 8 and 23% and the strands between roughly 5 and 13%. The effect of the epoxy resin mortar with respect to the impact indicators GWP, ODP and POCP can be neglected. It contributes 1.4 to 1.9% to the categories AP and NP, respectively. The effect of the mixing water of UHPC needs not be considered.

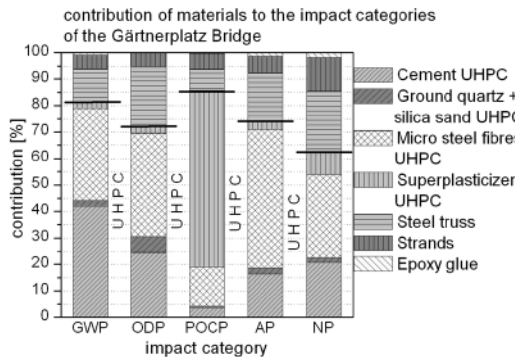

Figure 12. Contribution of materials to the environmental impact of Gärtnerplatz footbridge

### 3.4. Wapello Road Bridge (Mars Hill Bridge)

Figure 13 shows the results of the environmental impact assessment for the Wapello road bridge. The potential environmental impact by the production of the materials used for the Wapello road bridge is GWP100:  $8.74 \times 10^4$  kg CO<sub>2</sub> eq, ODP:  $3.5 \times 10^{-3}$  kg CFC-11 eq, POCP: 50.0 kg C<sub>2</sub>H<sub>4</sub> eq, AP: 264.0 kg SO<sub>2</sub> eq and NP: 39.9 kg PO<sub>4</sub><sup>3-</sup> eq.

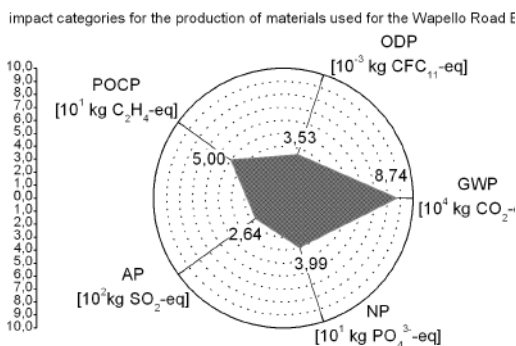

Figure 13. Results of the impact assessment for the materials used in Wapello road bridge

The contributions of the different materials to the potential environmental effect may be taken from the results of the dominance analysis, Figure 14. Depending on the impact category, the UHPC used

contributes between about 44 to 74% to the environmental effect of the Wapello road bridge. The bridge deck made with normal concrete and its reinforcing steel contribute about 15 to 34%, the strands roughly 10 to 22%.

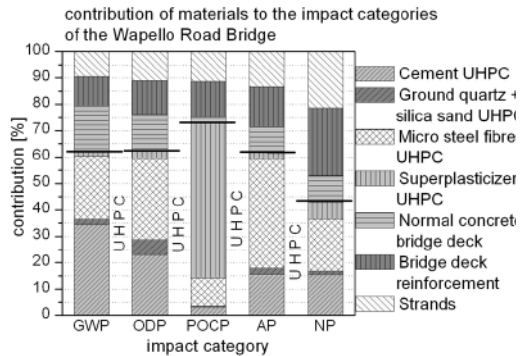

Figure 14. Contribution of materials to the environmental impact of Wapello Road Bridge

## 4. CONCLUSIONS

Ultra High Performance Concrete (UHPC) is an innovative upcoming cementitious material for the building industry. Typically, compressive strengths near 200 MPa and tensile strengths around 15 MPa are achieved by the use of a high cement content, a low water to cement ratio, a low maximum aggregate size and the addition of fine reactive components like silica fume. Due to the high load bearing capacity of UHPC, it is possible to reduce the cross sectional area of construction members and thus the weight of the construction as a whole. Hence on the one hand a smaller amount of raw materials is needed to build durable structures, but on the other hand the portion of energy-intensive constituents must be increased to guarantee the aforementioned properties. Thus a current research project at the Centre for Building Materials (cbm) at the Technical University of Munich (TUM) is concerned with the performance of a life cycle assessment (LCA) according to the ISO 14040 series for UHPC and structures made with UHPC. The project is part of a six year priority programme No. 1182 launched by the German Research Foundation (DFG) in 2005. The results presented here are a life cycle assessment (LCA) for the materials used in three different bridges made with UHPC. The investigated bridges are the Sherbrooke footbridge, the Kassel Gärtnerplatz footbridge and the Wapello Road Bridge (Mars Hill Bridge). The materials used for these bridges were modelled with



the help of the ecoinvent database which enabled the performance of a LCA with the SimaPro software. Values were determined for the impact categories global warming (GWP100), depletion of the stratospheric ozone (ODP), photo-oxidant formation i.e. summer smog (POCP), acidification (AP) and eutrophication (NP). In addition, dominance analyses were carried out for the environmental impacts of the three bridges. The results show that UHPC in the Sherbrooke footbridge and the Gärtnerplatz footbridge contributes about 60 to 85% of the environmental impact of these structures. In addition, considerable contributions are made by the steel web structure and the prestressing of the UHPC. In case of the Wapello road bridge, the contribution of UHPC to environmental impact is at the level of 44 to 74% somewhat lower. Besides UHPC, in particular the normal concrete in the bridge deck, the reinforcement of the bridge deck and the prestressing of the UHPC contribute appreciably to the effect on the environment. For all three bridges, the contributions of UHPC used may be attributed mainly to the cement, the micro steel fibres and the superplasticizer. With regard to the future development and application of UHPC, it is therefore recommended to reduce the content of steel fibres, cement and superplasticizer as much as possible. In the course of the research project other structures made of UHPC as well as conventional bridges are being analysed. The project aims at whether and how the use of UHPC in bridge construction can offer advantages over conventional building materials and structures regarding aspects of sustainability.

## ACKNOWLEDGEMENTS

The authors would like to thank the German Research Foundation (DFG) for the financial support within the priority programme No. 1182 "Sustainable Building with Ultra High Performance Concrete".

## REFERENCES

- [1] ISO 14041 (1998): Environmental management – Life Cycle Assessment – Goal and scope definition and inventory analysis
- [2] *Blais P.Y., Couture M.*; Precast, Prestressed Pedestrian Bridge – World's First Reactive Powder Concrete Structure, PCI Journal, September / October 1999, p.60-71
- [3] *Adeline R., Lachemi M., Blais P.Y.*; Design and behaviour of the Sherbrooke footbridge, Proceedings of the International Symposium on High Performance and Reactive Powder Concretes, 1998, Sherbrooke University, p.59-63
- [4] *Fehling E., Schmidt M., Bunje K., Schreiber W.*; Ultra High Performance Composite Bridge across the River Fulda in Kassel – Conceptual Design, Calculations and Invitation to Tender, Proceedings of the International Symposium on Ultra High Performance Concrete, 13.-15. September, 2004, Kassel University, p.69-75
- [5] *Borghoff M.*; The first European composite bridge made with UHPC in Kassel, Concrete Plant + Precast Technology (BFT International), Volume 72, No. 9, 2006, p.58-65
- [6] *Schmidt M., Bunje K., Fehling E., Teichmann T.*; Brückenfamilie aus Ultra-Hochfestem Beton in Niestetal und Kassel (UHPC bridges in the Nieste valley), Beton und Stahlbetonbau, Jahrgang 101, Heft 3, 2006, p.198-204 (in German)
- [7] *Schmidt M.*; Einsatz von UHPC beim Bau der Gärtnerplatzbrücke in Kassel (Usage of UHPC for the Gärtnerplatz bridge in Kassel), beton, Heft 6, 2007, p.252-254 (in German)
- [8] *Moore B., Bierwagen D.*; Ultra High Performance Concrete Highway Bridge, <http://www.cement.org/bookstore/profile.asp?itemid=IS736,07.01.2008>
- [9] *Nielsen R.J., Schmeckpeper E.R.*; Single-Span Prestressed Girder Bridge: LRFD Design and Comparison, Journal of Bridge Engineering, Volume 7, Issue 1, 2002, p.22-30
- [10] [www.pre.nl/simapro/](http://www.pre.nl/simapro/), 22<sup>nd</sup> October 2006
- [11] [www.ecoinvent.ch](http://www.ecoinvent.ch), 22<sup>nd</sup> October 2006
- [12] *Stengel T., Schiessl P.*; Life Cycle Assessment of the Production of High Strength Steel Fibres for Use in Ultra High Performance Concrete, The International Journal of Life Cycle Assessment, currently in press
- [13] *Stengel T., Schiessl P.*; Sustainable Construction with UHPC – from Life Cycle Inventory Data Collection to Environmental Impact Assessment, Proceedings of the International Symposium on Ultra High Performance Concrete, 05.-07. March, 2008, Kassel University

- [14] <http://www.cif.org/nom2007/nom-2007-09.pdf>, 15.01.2008
- [15] *Fehling E., Bunje K., Schmidt M., Tue N.V.*; Ultra High Performance Composite Bridge across the River Fulda in Kassel – Accompanying investigations according to the required agreement by the authorities, Proceedings of the International Symposium on Ultra High Performance Concrete, 13.-15. September, 2004, Kassel University, p.819-825
- [16] *Jerebic D.*; Vergleichende Öko-bilanzierung zur Gärtnerplatzbrücke in Kassel aus ultra-hochfestem Beton (Comparative LCA of the Gärtnerplatz bridge in Kassel), Diplomarbeit am Fachbereich Bauingenieurwesen der Universität Kassel, Kassel, Juni 2005 (in German)
- [17] *Schreiber W.*; Entwurf, Konstruktion und Bemessung der Gärtnerplatzbrücke, Tagungsbeiträge zu den 3 (Design and construction of the Gärtnerplatz bridge), Kasseler Baustoff- und Massivbautage, 2003, Universität Kassel, ISBN 3-89958-518-6, p.89-93 (in German)
- [18] *Tue N.V., Schneider H.*; Besonderheiten bei der Bemessung und der konstruktiven Ausbildung von Bauteilen aus UHPC im Rahmen der Zustimmung im Einzelfall (Design characteristics, construction and testing of members made from UHPC for a building-authority approval), Tagungsbeiträge zu den 3. Kasseler Baustoff- und Massivbautage, 2003, Universität Kassel, ISBN 3-89958-518-6, p.95-116 (in German)
- [19] *Schmidt M., Krelaus R., Teichmann T., Leutbecher T., Fehling E.*; Fügen von Bauteilen aus UHPC durch Kleben (Joining members made of UHPC by adhesive bonding), Beton und Stahlbetonbau, Jahrgang 102, Heft 10, 2007 p.681-690 (in German)
- [20] <http://www.bauingenieure-kassel.de/>, 15.01.2008
- [21] <http://www.imagineductal.com/imagineductal/public/eng/pdf/WapelloBridge.pdf>, 15.01.2008
- [22] [http://www.aspirebridge.org/pdfs/magazine/issue\\_03/mars\\_hill\\_sum07.pdf](http://www.aspirebridge.org/pdfs/magazine/issue_03/mars_hill_sum07.pdf), 15.01.2008
- [23] <http://www.wapellocounty.org/roads/marshill/special%20provisions.pdf>, 15.01.2008